

Trans-Amp

Product Data Sheet

Telephone: +44 (0) 1246 488 360
 Email: support@trans-amp.co.uk
 Website: www.trans-amp.co.uk

Great British Amplifier Transformers

Description	Fender Bassman Mains transformer	Part no.	TT3486	Issue no. 1
-------------	-------------------------------------	----------	--------	----------------

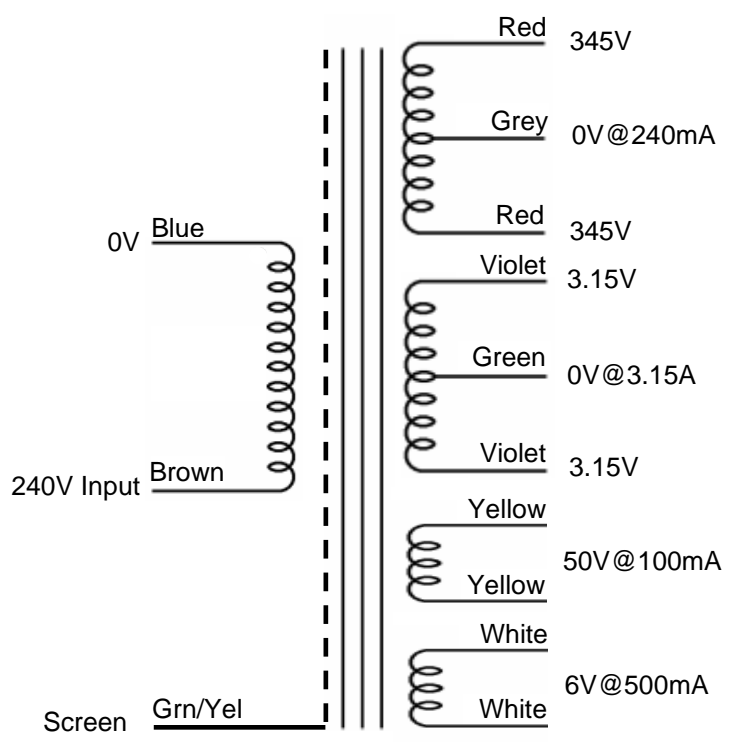
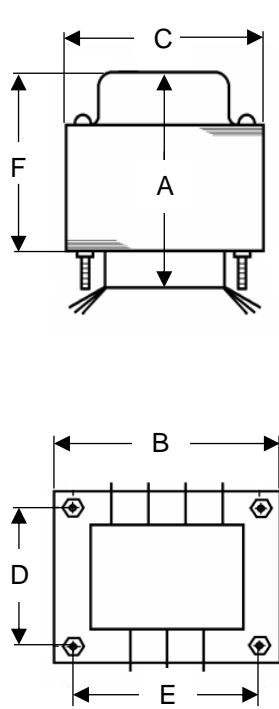

Dimensions in mm		Electrical Data	
A	100	Input voltage 50/60Hz	240V
B	114	HT open circuit voltage	359 - 0 - 359V
C	95	Heater open circuit voltage	6.6V Centre tapped
D	76	Rectifier heater open circuit voltage	6.2V
E	95	Bias open circuit voltage	52.8V
F	75	All leads 300mm long	

Raised by:	SW	Approved by:	DT	Date:	21/05/2015
------------	----	--------------	----	-------	------------



Warning: Electricity is dangerous and can cause death!
 If you are not qualified to install this product please consult a qualified, competent person
 Please be aware – You can still get an electric shock even if the appliance is disconnected!

Please note: This product may not be to the same specification for the model of amplifier you have. Please check the electrical specification on the datasheet BEFORE connecting. If you are unsure please consult a qualified, competent person.